

Scale Ring Sets

Assembly and Installation Example

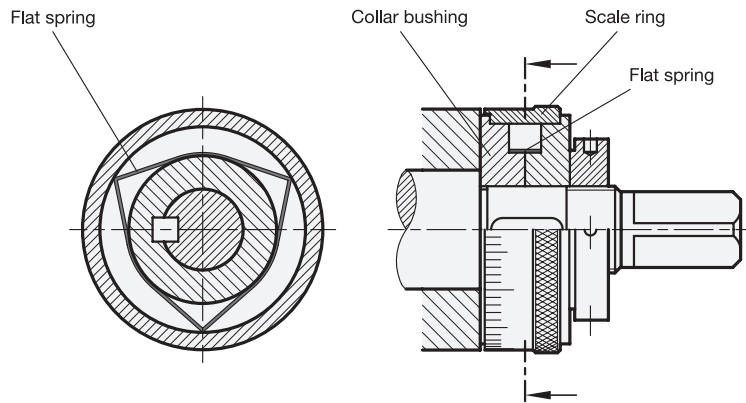

A complete scale ring set is composed of:

1 Scale ring	2 Collar bushings	3 Flat springs
GN 264-30	GN 268-24-K12	GN 374-0.3-10
GN 264-40	GN 268-32-K12	GN 374-0.4-10
GN 264-40	GN 268-32-K14	GN 374-0.4-10
GN 264-40	GN 268-32-K16	GN 374-0.4-10
GN 264-60	GN 268-50-K12	GN 374-0.6-10
GN 264-60	GN 268-50-K16	GN 374-0.6-10
GN 264-60	GN 268-50-K20	GN 374-0.6-10
GN 264-60	GN 268-50-K28	GN 374-0.6-10
GN 264-80	GN 268-68-K12	GN 374-0.8-10
GN 264-80	GN 268-68-K14	GN 374-0.8-10
GN 264-80	GN 268-68-K16	GN 374-0.8-10
GN 264-80	GN 268-68-K22	GN 374-0.8-10

Information

The scale ring set is used for the precision setting of all machine components which are adjustable via spindles.

All individual parts are made of steel. The flat springs are a perfect and virtually non-wearing connecting link between scale ring and spindle or collar bushings. When adjusting the spindle, they ensure that the scale ring is safely driven without impairing the setting options of the ring when the shaft is at rest.

The individual parts belonging to a scale ring set must be ordered separately.