

Constructional Features (Type A)

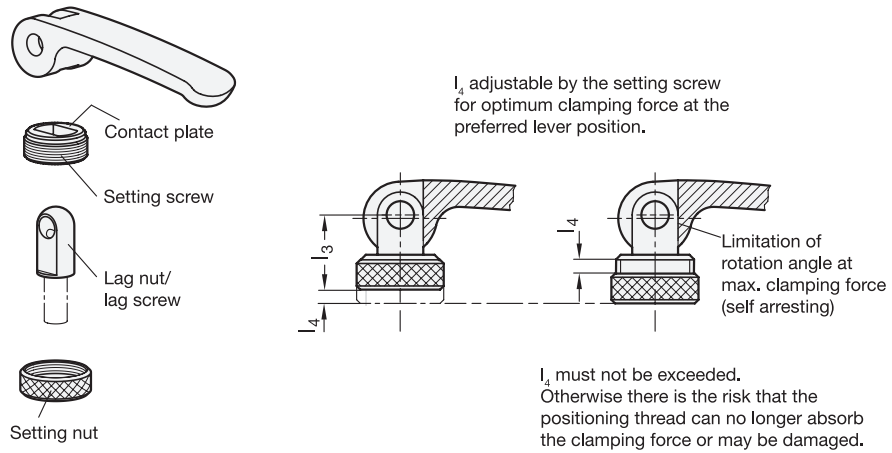

Application Example

