

2 Type

- VL** Clamping arm extended, with slotted hole and with two flanged washers
- VLC** Clamping arm extended, with slotted hole, two flanged washers and GN 708.1 spindle assembly

Operating principle

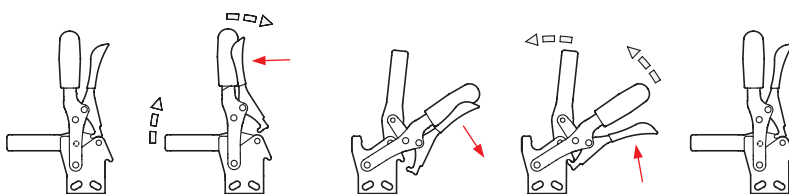

Specification

- Toggle clamp
Case-hardened steel C10
 - Zinc plated, blue passivated finish
 - Tempered bearing pins
 - Case-hardened bearing rivets
- All moving parts lubricated with special grease
- Hand grip
High quality, oil resistant red plastic
- Spindle assembly GN 708.1, Type A
→ page 858
 - Steel, zinc plated, blue passivated finish
 - Rubber tip 85 shore A
- RoHS compliant

Accessory

- Spindle assemblies → starting from page 856
- Clamp mounts GN 801 (for type VL)
→ www.jwwinco.com
- Clamping arm extenders GN 801.1 (for type VL)
→ page 860
- Clamping arm extenders GN 801.2 (for type VL)
→ page 861

Information

GN 810.4 extended arm vertical acting toggle clamps have a safety function whereby, during closing, a spring loaded safety hook arm ensures a secure locking connection. It prevents the inadvertent unlocking of the clamp due to vibrations or an accidental attempt of loosening / opening of the clamp. To open and release the toggle clamp from the locked closed position, press the lever arm and safety hook lever arm together (one hand operation). The toggle clamp is then in the open position which can also be locked temporarily in that position via the hook of the safety hook lever arm to avoid inadvertent closing of the clamp.

They work according to the toggle principle: lever and clamping bar move in the same direction. In the clamped position the operating lever is in its vertical position.

Extended arm vertical acting toggle clamps in the U-bar version with two flanged washers (Type VL) can accommodate an application specific clamping screw. A spindle assembly with neoprene rubber tip is also included for Type VLC.

see also...

- General Information on Toggle Clamps → page 756
- Vertical Acting Toggle Clamps GN 810.10 (Heavy Duty Type „Longlife“) → page 770
- Extended Arm Vertical Acting Toggle Clamps GN 810.3 → page 764

<p>How to order</p> <p>GN810.4-230-VLC</p>	1	Size
	2	Type

Universal table



Dimensions in: millimeters - inches

Size	F _H Holding capacity	a ≈	b ₁	b ₂	b ₃	b ₄	d ₁	d ₂ ≈	h ₁ ≈	h ₂	h ₃	h ₄	h ₅ max.
130	500 N 112 lbf	67.5 2.66	35 1.38	10 0.39	5 0.20	6.3 0.25	M 6	5.5 0.22	156 6.14	41.5 1.63	16 0.63	25.5 1.00	25 0.98
230	1000 N 225 lbf	71.5 2.81	43 1.69	12 0.47	6 0.24	8.2 0.32	M 8	6.5 0.26	183 7.20	48 1.89	18 0.71	30 1.18	24 0.94

Size	l ₁ ≈	l ₂ ≈	l ₃	m ₁	m ₂	m ₃	m ₄	r ≈	w Adjustable range
130	164 6.46	121 4.76	55 2.17	12.5 0.49	19 0.75	6.5 0.26	7.5 0.30	158 6.22	17.5 0.69
230	198 7.80	145.5 5.73	68 2.68	19.5 0.77	19.5 0.77	6.5 0.26	6.5 0.26	191 7.52	20 0.79

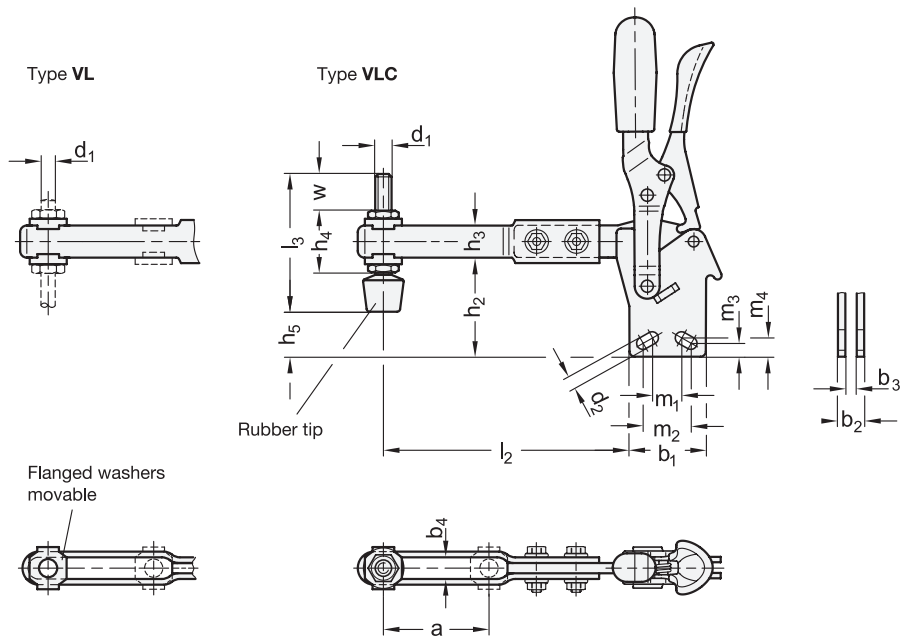

1.1
1.2
1.3
1.4
2.1
2.2
2.3
2.4

