

**2 Type**

- B** Clamping bar with slotted hole (only size 220 and 440)
- F** Clamping bar with bushing

**Metric table**



Dimensions in: millimeters - inches

Size	F <sub>H</sub> Holding capacity	a	b <sub>1</sub>	b <sub>2</sub>	b <sub>3</sub>	b <sub>4</sub>	d <sub>1</sub> Thread	d <sub>2</sub>	d <sub>3</sub>	h <sub>1</sub>	h <sub>2</sub>	h <sub>3</sub>	h <sub>4</sub> ≈
220	2200 N 495 lbf	32 1.26	36 1.42	13 0.51	6 0.24	6 0.24	M 6	6.5 0.26	6.5 0.26	152 5.98	45.5 1.79	16 0.63	27 1.06
440	4400 N 989 lbf	34 1.34	54 2.13	20 0.79	10 0.39	10 0.39	M 10	8.5 0.33	10.5 0.41	235 9.25	69.5 2.74	24 0.94	45 1.77
850*	8500 N 1911 lbf	-	75 2.95	24 0.94	-	12 0.47	M 12	10.5 0.41	12.5 0.49	301 11.85	88 3.46	30 1.18	-
1540*	15400 N 3462 lbf	-	90 3.54	32 1.26	-	16 0.63	M 16	12.5 0.49	16.5 0.65	344 13.54	106 4.17	35 1.38	-

Size	l <sub>1</sub>		l <sub>2</sub>	l <sub>3</sub>	m <sub>1</sub>	m <sub>2</sub>	m <sub>3</sub>	r <sub>1</sub>	r <sub>2</sub>	s
	Type B	Type F								
220	91 3.58	86 3.39	51 2.01	46 1.81	20 0.79	8 0.31	8 0.31	77 3.03	72 2.83	6 0.24
440	129.5 5.10	129.5 5.10	66 2.60	66 2.60	30 1.18	10 0.39	12 0.47	107 4.21	107 4.21	10 0.39
850*	-	161 6.34	-	72 2.83	55 2.17	10 0.39	10 0.39	-	133 5.24	12 0.47
1540*	-	203 7.99	-	92.5 3.64	65 2.56	17.5 0.69	12.5 0.49	-	167 6.57	16 0.63

\* This size is fitted with a round handle at the lever arm and available only in Type F.

**Specification**

- Toggle clamp  
Steel
  - Precision casting
  - Blackened finish
- Lever arm  
Steel
  - Forged
  - Blackened finish
- Parts in sheet metal  
Case-hardened steel, blackened finish
- Bearing pins and rivets  
Steel, hardened and ground
- All moving parts  
Lubricated with special grease
- Hand grip  
High quality, oil resistant red plastic
- RoHS compliant

**Accessory**

- Clamping screws → page XYZ

**Information**

Vertical acting toggle clamps „Longlife“ GN 810.11 can accommodate an application-specific screw or assembly.

Vertical acting toggle clamps GN 810.11 are an advance development of GN 810.1. The steel sheet design of the clamp and lever arms is replaced by precision or die-forged components. The remaining steel sheet metal parts have been reinforced, bearing pins and rivets are hardened and ground.

Therefore these clamps are suitable for applications in which substantial forces occur and a long service life is required.

During extensive testing, with trouble free function and under load, the clamp has withstood over one million opening and closing cycles.

Flanged washers are included, toggle clamp spindle assemblies are not included.

see also...

- General Information on Toggle Clamps → page 756
- Vertical Acting Toggle Clamps GN 810.1 (with Vertical Mounting Base) → page 760

<b>How to order</b>	1	Size
	2	Type

**GN 810.11-440-F**

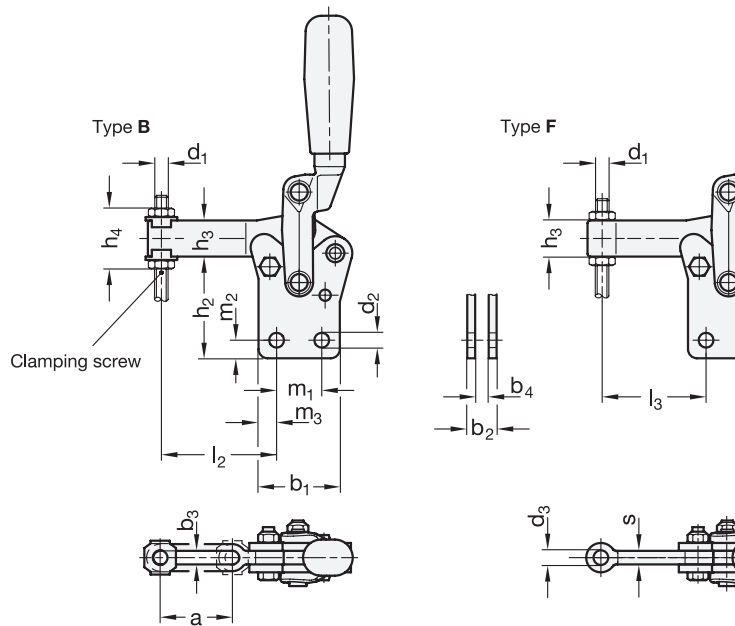

1.1

1.2

1.3

1.4

2.1

2.2

2.3

2.4

