

5 Type

A Without screws

Metric table

1	2	3	4								
s ₁	s ₂	n	d ₁		d ₂ For screw	h ₁	h ₂	m ₁	m ₂	Grid size	
30 1.18	60 2.36	8 0.31	M 10	M 12	M 8 / S 8	12 0.47	3.2 0.13	30 1.18	-	30 1.18	
40 1.57	80 3.15	10 0.39	M 10	M 12	M 12 / S 12	16 0.63	8 0.31	40 1.57	-	40 1.57	
45 1.77	90 3.54	10 0.39	M 12	M 14	M 12 / S 12	16 0.63	8 0.31	45 1.77	-	45 1.77	
80 3.15	80 3.15	10 0.39	M 12	M 16	M 12 / S 12	16 0.63	8 0.31	40 1.57	40 1.57	40 1.57	
90* 3.54	90 3.54	10 0.39	M 16	M 20	M 12 / S 12	16 0.63	8 0.31	45 1.77	45 1.77	45 1.77	

Dimensions in: millimeters - inches

* Only compatible with profile type L

Specification

- Zinc die-cast, black
- RoHS



ZS

Accessory

- Central Screws GN 21b → page XYZ

Information

Support / base plates GN 80b affix attachments such as leveling feet or castors to aluminum profiles.

They are installed in the profile holes on the end faces using suitably tapped threaded holes or thread-forming screws.

see also...

- Aluminum Profiles GN 10b (Profile Type Light) → page QVX
- Aluminum Profiles GN 10b (Profile Type Heavy) → page QVX

How to order	
1	Width s ₁
2	Length s ₂
3	Slot width n
4	Thread d ₁
5	Type
6	Material / Color

GN 80b-45 90 10M12-A-ZS

Assembly Instructions / Profile Machining

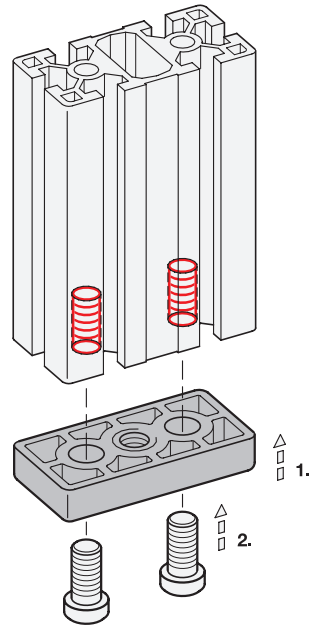
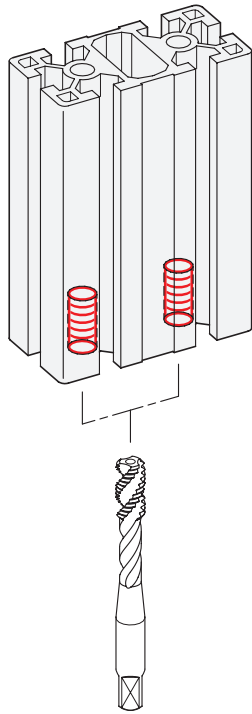

3.1

3.2

3.3

3.4

3.5

3.6

3.7

3.8

3.9

3.10

