

1.1
1.2
1.3
1.4
2.1
2.2
2.3
2.4

Mounting information

- 1) Drill the handle housing according to the template dimensions reported in the table.
- 2) Remove all drill hole burrs before assembling the handle.
- 3) Fit the upper part of the handle into the housing and press onto the lower part until firmly in place.
- 4) Gently push the handle downward.
- 5) Screw in the two self-tapping screws.
- 6) Assemble the screw cover by pressing on the lateral sides first and finally on the central part.

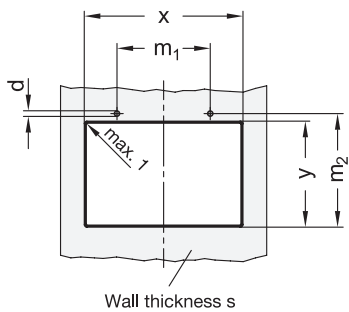
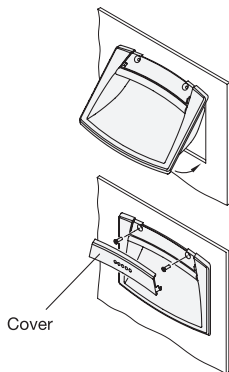

s Wall thickness	d ±0.02 For self-tapping screw	For M3	m ₁ ±0.1			m ₂ ±0.1		x +0.2		y +0.5	
			b ₁ =110 b ₁ =120	b ₁ =110	b ₁ =120	b ₁ =110	b ₁ =120	b ₁ =110	b ₁ =120		
1 ... 1.2 0.04 ... 0.05	2.5 0.098	Core hole drilling 2.5 mm (0.098 in) Through-bore hole 3.2 mm (0.126 in)	64 2.52	55.5 2.19	76.8 3.02	100 3.94	107.5 4.23	52 2.05	73 2.87		
> 1.2 ... 1.5 0.05 ... 0.06	2.55 0.1		64 2.52	55.5 2.19	77 3.03	100 3.94	107.5 4.23	52.2 2.06	73 2.87		
> 1.5 ... 2 0.06 ... 0.08	2.6 0.102		64 2.52	56 2.20	77.2 3.04	100 3.94	107.5 4.23	52.5 2.07	73 2.87		
> 2 ... 2.5 0.06 ... 0.08	2.65 0.104		64 2.52	56.2 2.21	77.5 3.05	100 3.94	107.5 4.23	52.7 2.08	74 2.91		
> 2.5 ... 3 0.08 ... 0.12	2.65 0.104		64 2.52	56.5 2.22	77.8 3.06	100 3.94	107.5 4.23	53 2.09	74 2.91		
> 3 ... 3.5 0.12 ... 0.14	2.7 0.106		64 2.52	56.7 2.23	78.1 3.07	100 3.94	107.5 4.23	53.2 2.1	74 2.91		
> 3.5 ... 4 0.14 ... 0.16	2.7 0.106		64 2.52	56.9 2.24	78.4 3.09	100 3.94	107.5 4.23	53.4 2.1	75 2.95		
> 4 ... 4.5 0.16 ... 0.18	2.7 0.106		64 2.52	57.1 2.25	78.7 3.1	100 3.94	107.5 4.23	53.6 2.11	75 2.95		
> 4.5 ... 5 0.18 ... 0.2	2.7 0.106		64 2.52	57.3 2.26	79 3.11	100 3.94	107.5 4.23	53.8 2.12	75 2.95		

