

Metric

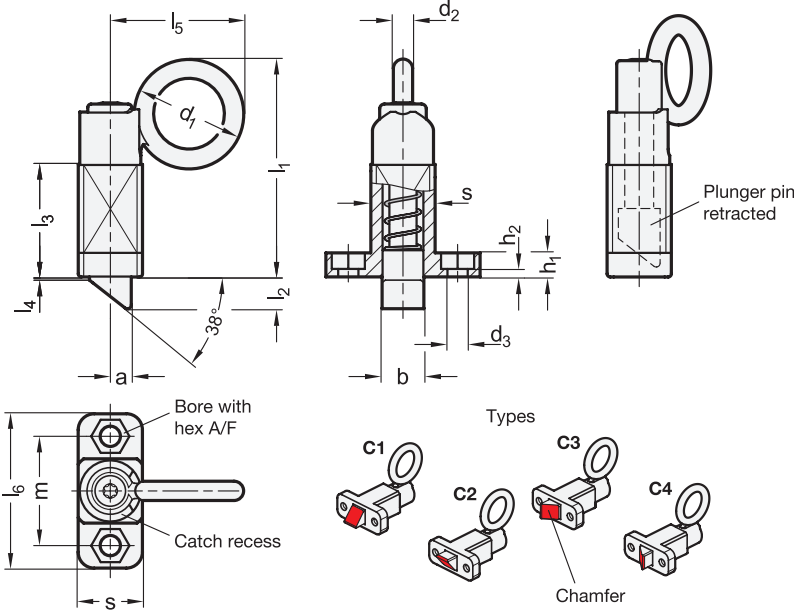

SS Stainless Steel

3 Type

- C1** Chamfer, top
- C2** Chamfer, bottom
- C3** Chamfer, right
- C4** Chamfer, left

Metric table

Dimensions in: millimeters / inches

b	s	a	d ₁	d ₂	d ₃	h ₁	h ₂	l ₁ ≈	l ₂	l ₃	l ₄	l ₅	l ₆	m	A/F	Spring load ≈	
																Initial	End
13 0.51	20 0.79	6.5 0.26	34 1.34	6 0.24	6.1 0.240	7.5 0.30	1.5 0.06	68 2.68	10 0.39	35 1.38	1 0.04	41.5 1.63	48 1.89	34 1.34	10 0.39	14 N 3.15 lbf	35 N 7.87 lbf
20 0.79	30 1.18	10 0.39	48 1.89	9 0.35	10.1 0.398	15 0.59	5 0.20	102 4.02	15 0.59	54 2.13	1.5 0.06	60 2.36	80 3.15	55 2.17	17 0.67	22 N 4.95 lbf	70 N 15.74 lbf

Specification

Guide

- Steel precision casting
- Zinc plated, blue passivated finish **ZB**
- Zinc plated and powder coated **SW**
- Black, RAL 9005, textured finish
- Stainless steel precision casting AISI CF-8 **NI**

Pull ring

- Steel precision casting
- Zinc plated, blue passivated finish (for ZB and SW)
- Stainless steel precision casting AISI CF-8 (for NI)

Plunger pin

- Steel, hardened
- Zinc plated, blue passivated finish (for ZB and SW)
- Stainless steel AISI 431, hardened (for NI)

Compression spring

Stainless steel AISI 316Ti

RoHS

Technical Information

Page

List of Indexing Plunger Types	QVX
Stainless Steel Characteristics	QVX

Indexing plungers GN 724.5 have a plunger pin with square cross-section, a latching surface on one side and a chamfer on the other. When the object to be secured moves towards the chamfer, the plunger pin is pushed back into the guide, allowing grooves and edges to pass over the pin. The plunger pin engages automatically in the direction of the latching surface.

The latching can be released by pulling the pull ring by hand or with a cable or pull rod using a hook. The types with lock-out are used when the plunger pin should temporarily not protrude. For this purpose, the pull ring is turned sideways after the plunger pin has been retracted. The ring is held in this position by the catch recess at the top of the guide.

The dimensional tolerances between the pin and the guide have been chosen to ensure functional reliability even in roughly dimensioned applications or in the event of soiling.

There are several options for fastening. The hex mounting holes allow the use of socket cap screws DIN 912 and hex head screws or nuts according to DIN 931 or DIN 934.

How to order

GN 724.5-20-30-C2-NI

1	Pin diameter b
2	Square s
3	Type
4	Material (Finish)