

SS Stainless Steel

- 2** **Type**
- A** With plastic knob, without lock nut
 - AK** With plastic knob, with lock nut
 - AN*** With stainless steel knob, without lock nut
 - AKN*** With stainless steel knob, with lock nut

Metric table

1

Dimensions in: millimeters - inches

d ₁ Pin -0.02 Bore H7	d ₂	d ₃	e	l ₁	l ₂	l ₃	l ₄	l ₅	A/F	w ₁	w ₂	Spring load ≈	
												Initial	End
6 0.24	M 12 x 1.5	19 0.75	15 0.59	6 0.24	38 1.50	20 0.79	44.5 1.75	9 0.35	13 0.51	3 0.12	9 0.35	8.5 N 1.91 lbf	25 N 5.62 lbf
8 0.31	M 16 x 1.5	25 0.98	19 0.75	8 0.31	46 1.81	26 1.02	54.5 2.15	11 0.43	17 0.43	3 0.12	11 0.67	18 N 4.05 lbf	44 N 9.89 lbf

* only available in version A4

Specification

3

- Threaded body
Steel, blackened finish —
- Plunger pin
Steel, nitrided
- Compression spring
Stainless steel AISI 301

- Threaded body
Stainless steel AISI 316 **A4**
- Plunger pin
Stainless steel AISI 316
- Compression spring
Case hardened
- Compression spring
Stainless steel AISI 316Ti

- Knob (Type A / AK)
Plastic
Technopolymer (Polyamide PA)
- Black, matte finish
- Not removable

- Knob (Type AN / AKN)
Stainless steel AISI 316
Not removable

- Load Rating Information → page 2103
- ISO Fundamental Tolerances → page 2129
- Plastic Characteristics → page 2135
- Stainless Steel Characteristics → Page QVX
- RoHS compliant

Information

Locking indexing plungers GN 514 feature a cardioid curve mechanism based on the principle of a retractable pen. They offer very ergonomic operation that requires only repeated pressing of the knob. Thanks to their functional principle, they are well suited for use in tight conditions and are also easy to protect against improper operation, if necessary.

First the plunger pin is brought into the protruding position by pressing the knob. In this position, the cardioid curve mechanism automatically engages to lock the part. Pressing the knob again unlocks the mechanism since the plunger pin retracts automatically by spring force once the button is released. The plunger pin must not be subjected to any axial forces and must move easily.

The stainless steel design is suitable for applications in highly corrosive environments thanks to the A4 materials used.

see also...

- List of Indexing Plunger Types → page 915
- Spacer Bushings GN 609.5 (to Limit the Thread Length) → page 994
- Locating Bushings GN 412.2 / GN 412.4 → page 996
- Thin Hex Nuts GN 909 / GN 909.5 → page 995

How to order (Steel, with plastic knob)	1 Pin diameter d ₁
	2 Type
GN 514-8-A	

How to order (Stainless steel, with SST knob)	1 Pin diameter d ₁
	2 Type
	3 Material
GN 514-6-AKN-A4	

Description of function

1. In the protruding position, the plunger pin protrudes by distance l_1 and is locked.
2. The knob is pressed by distance w_1 , thereby unlocking the plunger pin.
3. Then the plunger pin is retracted by the compression spring and held in the retracted position.
4. The knob is pressed by distance w_2 and locks again in the protruding position after release.

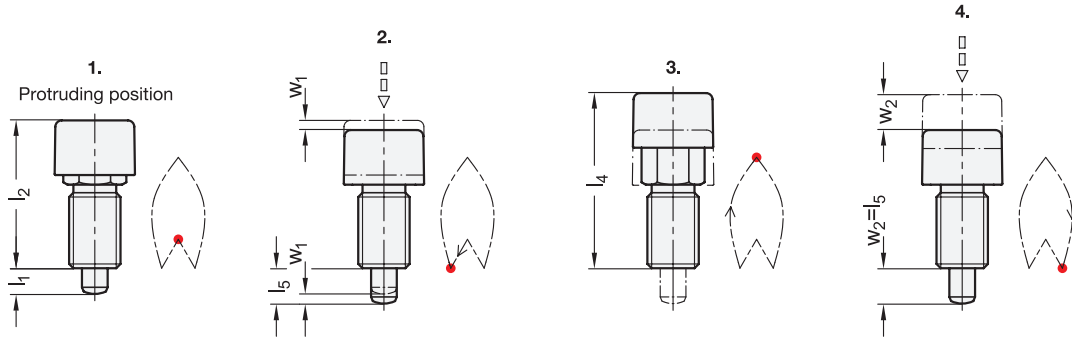

Application examples

