

**Application examples**

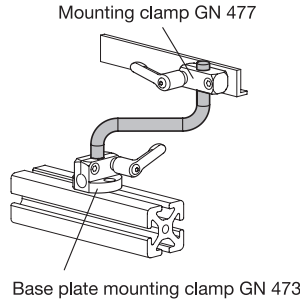
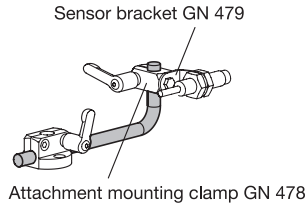

SS Stainless Steel

**Metric table**

Dimensions in: millimeters - inches

1 GN 480.3 d Diameter	2 l <sub>1</sub>	3 l <sub>2</sub>
D 8	30 1.18	90 3.54
D 8	50 1.97	150 5.91
D 8	80 3.15	240 9.45
D 10	50 1.97	150 5.91
D 10	70 2.76	210 8.27
D 10	100 3.94	300 11.81

1 GN 480.5 d Diameter	2 l <sub>1</sub>	3 l <sub>2</sub>
D 8	30 1.18	60 2.36
D 8	50 1.97	100 3.94
D 8	80 3.15	160 6.30
D 10	50 1.97	100 3.94
D 10	70 2.76	140 5.51
D 10	100 3.94	200 7.87

**Specification**

- Stainless steel AISI 304 **NI**  
Plain finish
- Stainless Steel Characteristics → page QVX
- RoHS compliant

**Information**

The dimensions of GN 480.3 / GN 480.5 adjusting rods are tailored for use with mounting clamps. The cranked / angled adjusting rods make it possible to create compact and space-saving mounting clamp structures efficiently and cost-effectively with few components.

see also...

- Rods / Tubes GN 480.1 → page QVX

**On request**

- Additional lengths for l<sub>1</sub> and l<sub>2</sub>

How to order (Angled)	1 Diameter d
1 2 3 4	2 Length l <sub>1</sub>
<b>GN 480.3-D8-30-90-NI</b>	3 Length l <sub>2</sub>
	4 Material

How to order (Cranked)	1 Diameter d
1 2 3 4	2 Length l <sub>1</sub>
<b>GN 480.5-D8-80-160-NI</b>	3 Length l <sub>2</sub>
	4 Material

3.1  
3.2  
3.3  
3.4  
3.5  
3.6  
3.7  
3.8  
3.9  
3.10