

**4 Type (Base)**

- A1** Steel, zinc plated, rubber pad inlay, black
- A5** Steel, black powder coated, rubber pad inlay, black

**Inch table**

1 d <sub>1</sub>	2 d <sub>2</sub>	3								3 Dimensions in: inches - millimeters			
		Version S / SK				Version U / UK				Version X	h <sub>1</sub>	l <sub>8</sub>	l <sub>9</sub>
1.97 50	5/16 x 18	-	-	-	-	-	-	-	-	1.57 40	0.71 18	0.98 25	1.77 45
1.97 50	3/8 x 16	2.95 75	3.94 100	4.92 125	5.91 150	-	-	-	-	1.69 43	0.71 18	0.98 25	1.77 45
1.97 50	1/2 x 13	2.95 75	3.94 100	4.92 125	5.91 150	-	-	-	-	1.85 47	0.71 18	0.98 25	1.77 45
1.97 50	5/8 x 11	-	-	-	-	2.95 75	3.94 100	4.92 125	5.91 150	2.05 52	0.71 18	0.98 25	1.77 45
2.36 60	5/16 x 18	-	-	-	-	-	-	-	-	1.61 41	0.75 19	0.98 25	1.97 50
2.36 60	3/8 x 16	2.95 75	3.94 100	4.92 125	5.91 150	-	-	-	-	1.73 44	0.75 19	0.98 25	1.97 50
2.36 60	1/2 x 13	2.95 75	3.94 100	4.92 125	5.91 150	-	-	-	-	1.89 48	0.75 19	0.98 25	1.97 50
2.36 60	5/8 x 11	-	-	-	-	2.95 75	3.94 100	4.92 125	5.91 150	2.09 53	0.75 19	0.98 25	1.97 50
3.15 80	5/16 x 18	-	-	-	-	-	-	-	-	1.65 42	0.79 20	1.18 30	2.76 70
3.15 80	3/8 x 16	2.95 75	3.94 100	4.92 125	5.91 150	-	-	-	-	1.77 45	0.79 20	1.18 30	2.76 70
3.15 80	1/2 x 13	2.95 75	3.94 100	4.92 125	5.91 150	-	-	-	-	1.93 49	0.79 20	1.18 30	2.76 70
3.15 80	5/8 x 11	-	-	-	-	2.95 75	3.94 100	4.92 125	5.91 150	2.13 54	0.79 20	1.18 30	2.76 70
3.15 80	3/4 x 10	-	-	-	-	3.94 100	4.92 125	5.91 150	-	2.44 62	0.79 20	1.18 30	2.76 70
3.94 100	5/16 x 18	-	-	-	-	-	-	-	-	1.69 43	0.83 21	1.18 30	3.15 80
3.94 100	3/8 x 16	2.95 75	3.94 100	4.92 125	5.91 150	-	-	-	-	1.81 46	0.83 21	1.18 30	3.15 80
3.94 100	1/2 x 13	2.95 75	3.94 100	4.92 125	5.91 150	-	-	-	-	1.97 50	0.83 21	1.18 30	3.15 80
3.94 100	5/8 x 11	-	-	-	-	2.95 75	3.94 100	4.92 125	5.91 150	2.17 55	0.83 21	1.18 30	3.15 80
3.94 100	3/4 x 10	-	-	-	-	3.94 100	4.92 125	5.91 150	-	2.48 63	0.83 21	1.18 30	3.15 80

d <sub>1</sub>	d <sub>2</sub>	h <sub>3</sub>	h <sub>4</sub>	A/F <sub>1</sub>	A/F <sub>2</sub>	A/F <sub>3</sub>	A/F <sub>7</sub>	t
1.97 50	5/16 x 18	-	-	-	-	-	1/2	0.31 8
1.97 50	3/8 x 16	1.02 26	-	11/16	-	-	1/2	0.39 10
1.97 50	1/2 x 13	1.02 26	-	11/16	-	-	5/8	0.47 12
1.97 50	5/8 x 11	-	1.26 32	-	1/2	5/16	7/8	0.63 16
2.36 60	5/16 x 18	-	-	-	-	-	1/2	0.31 8
2.36 60	3/8 x 16	1.06 27	-	11/16	-	-	1/2	0.39 10
2.36 60	1/2 x 13	1.06 27	-	11/16	-	-	5/8	0.47 12
2.36 60	5/8 x 11	-	1.30 33	-	1/2	5/16	7/8	0.63 16
3.15 80	5/16 x 18	-	-	-	-	-	1/2	0.31 8
3.15 80	3/8 x 16	1.10 28	-	11/16	-	-	1/2	0.39 10
3.15 80	1/2 x 13	1.10 28	-	11/16	-	-	5/8	0.47 12
3.15 80	5/8 x 11	-	1.34 34	-	1/2	5/16	7/8	0.63 16
3.15 80	3/4 x 10	-	1.38 35	-	9/16	7/16	1	0.79 20
3.94 100	5/16 x 18	-	-	-	-	-	1/2	0.31 8
3.94 100	3/8 x 16	1.14 29	-	11/16	-	-	1/2	0.39 10
3.94 100	1/2 x 13	1.14 29	-	11/16	-	-	5/8	0.47 12
3.94 100	5/8 x 11	-	1.38 35	-	1/2	5/16	7/8	0.63 16
3.94 100	3/4 x 10	-	1.42 36	-	9/16	7/16	1	0.79 20

**Stud / socket versions**

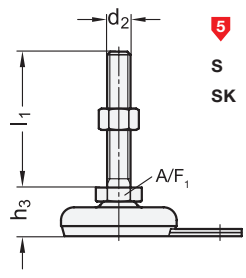

**S** Without nut  
**SK** With nut

External hex at the bottom at d<sub>2</sub>  
3/8 x 16, 1/2 x 13  
M 8, M 10, M 12

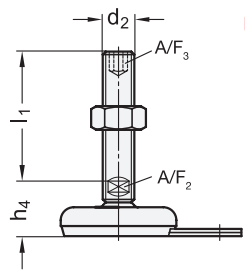

**U** Without nut  
**UK** With nut

Internal hex at the top, wrench flat at the bottom at d<sub>2</sub>  
5/8 x 11, 3/4 x 10  
M 16, M 20, M 24

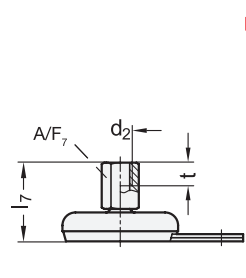

**X** Tapped socket type

External hex with tapped socket at d<sub>2</sub>  
5/16 x 18, 3/8 x 16, 1/2 x 13, 5/8 x 11, 3/4 x 10  
M 8, M 10, M 12, M 16, M 20

3.1  
3.2  
3.3  
3.4  
3.5  
3.6  
3.7  
3.8  
3.9  
3.10



**Metric table**

**1** **2** **3** **3** Dimensions in: millimeters - inches

d <sub>1</sub>	d <sub>2</sub>	l <sub>1</sub>					Version U / UK						l <sub>7</sub> Version X	h <sub>1</sub>	l <sub>8</sub>	l <sub>9</sub>
		Version S / SK														
50 1.97	M 8	40 1.57	50 1.97	63 2.48	-	-	-	-	-	-	-	-	40 1.57	18 0.71	25 0.98	45 1.77
50 1.97	M 10	50 1.97	60 2.36	80 3.15	100 3.94	-	-	-	-	-	-	-	43 1.69	18 0.71	25 0.98	45 1.77
50 1.97	M 12	60 2.36	80 3.15	100 3.94	125 4.92	-	-	-	-	-	-	-	47 1.85	18 0.71	25 0.98	45 1.77
50 1.97	M 16	-	-	-	-	75 2.95	100 3.94	125 4.92	150 5.91	200 7.87	250 9.84	-	52 2.05	18 0.71	25 0.98	45 1.77
60 2.36	M 8	40 1.57	50 1.97	63 2.48	-	-	-	-	-	-	-	-	41 1.61	19 0.75	25 0.98	50 1.97
60 2.36	M 10	50 1.97	60 2.36	80 3.15	100 3.94	-	-	-	-	-	-	-	44 1.73	19 0.75	25 0.98	50 1.97
60 2.36	M 12	60 2.36	80 3.15	100 3.94	125 4.92	-	-	-	-	-	-	-	48 1.89	19 0.75	25 0.98	50 1.97
60 2.36	M 16	-	-	-	-	75 2.95	100 3.94	125 4.92	150 5.91	200 7.87	250 9.84	-	53 2.09	19 0.75	25 0.98	50 1.97
80 3.15	M 8	40 1.57	50 1.97	63 2.48	-	-	-	-	-	-	-	-	42 1.65	20 0.79	30 1.18	70 2.76
80 3.15	M 10	50 1.97	60 2.36	80 3.15	100 3.94	-	-	-	-	-	-	-	45 1.77	20 0.79	30 1.18	70 2.76
80 3.15	M 12	60 2.36	80 3.15	100 3.94	125 4.92	-	-	-	-	-	-	-	49 1.93	20 0.79	30 1.18	70 2.76
80 3.15	M 16	-	-	-	-	75 2.95	100 3.94	125 4.92	150 5.91	200 7.87	250 9.84	-	54 2.13	20 0.79	30 1.18	70 2.76
80 3.15	M 20	-	-	-	-	75 2.95	100 3.94	125 4.92	150 5.91	200 7.87	250 9.84	-	62 2.44	20 0.79	30 1.18	70 2.76
80 3.15	M 24	-	-	-	-	100 3.94	125 4.92	150 5.91	200 7.87	300 11.81	-	-	20 0.79	30 1.18	70 2.76	
100 3.94	M 8	40 1.57	50 1.97	63 2.48	-	-	-	-	-	-	-	-	43 1.69	21 0.83	30 1.18	80 3.15
100 3.94	M 10	50 1.97	60 2.36	80 3.15	100 3.94	-	-	-	-	-	-	-	46 1.81	21 0.83	30 1.18	80 3.15
100 3.94	M 12	60 2.36	80 3.15	100 3.94	125 4.92	-	-	-	-	-	-	-	50 1.97	21 0.83	30 1.18	80 3.15
100 3.94	M 16	-	-	-	-	75 2.95	100 3.94	125 4.92	150 5.91	200 7.87	250 9.84	-	55 2.17	21 0.83	30 1.18	80 3.15
100 3.94	M 20	-	-	-	-	75 2.95	100 3.94	125 4.92	150 5.91	200 7.87	250 9.84	-	63 2.48	21 0.83	30 1.18	80 3.15
100 3.94	M 24	-	-	-	-	100 3.94	125 4.92	150 5.91	200 7.87	300 11.81	-	-	21 0.83	30 1.18	80 3.15	

d <sub>1</sub>	d <sub>2</sub>	h <sub>3</sub>	h <sub>4</sub>	A/F <sub>1</sub>	A/F <sub>2</sub>	A/F <sub>3</sub>	A/F <sub>7</sub>	t
50 1.97	M 8	26 1.02	-	17 0.67	-	-	14 0.55	8 0.31
50 1.97	M 10	26 1.02	-	17 0.67	-	-	14 0.55	10 0.39
50 1.97	M 12	26 1.02	-	17 0.67	-	-	17 0.67	12 0.47
50 1.97	M 16	-	32 1.26	-	12 0.47	8 0.31	22 0.87	16 0.63
60 2.36	M 8	27 1.06	-	17 0.67	-	-	14 0.55	8 0.31
60 2.36	M 10	27 1.06	-	17 0.67	-	-	14 0.55	10 0.39
60 2.36	M 12	27 1.06	-	17 0.67	-	-	17 0.67	12 0.47
60 2.36	M 16	-	33 1.30	-	12 0.47	8 0.31	22 0.87	16 0.63
80 3.15	M 8	28 1.10	-	17 0.67	-	-	14 0.55	8 0.31
80 3.15	M 10	28 1.10	-	17 0.67	-	-	14 0.55	10 0.39
80 3.15	M 12	28 1.10	-	17 0.67	-	-	17 0.67	12 0.47
80 3.15	M 16	-	34 1.34	-	12 0.47	8 0.31	22 0.87	16 0.63
80 3.15	M 20	-	35 1.38	-	15 0.59	10 0.39	27 1.06	20 0.79
80 3.15	M 24	-	38 1.50	-	19 0.75	12 0.47	-	-
100 3.94	M 8	29 1.14	-	17 0.67	-	-	14 0.55	8 0.31
100 3.94	M 10	29 1.14	-	17 0.67	-	-	14 0.55	10 0.39
100 3.94	M 12	29 1.14	-	17 0.67	-	-	17 0.67	12 0.47
100 3.94	M 16	-	35 1.38	-	12 0.47	8 0.31	22 0.87	16 0.63
100 3.94	M 20	-	36 1.42	-	15 0.59	10 0.39	27 1.06	20 0.79
100 3.94	M 24	-	39 1.54	-	19 0.75	12 0.47	-	-

**Specification**

- Base / flange  
Steel sheet metal  
- Type A1  
Zinc plated, blue passivated finish  
- Type A5  
Powder coated, black, RAL 9005
- Threaded stud / tapped socket  
Steel, zinc plated, blue passivated finish
- Inch size hex nut ANSI / ASME B18.2.2  
Steel, zinc plated, blue passivated finish
- Metric size hex nut ISO 4032  
Steel, zinc plated, blue passivated finish
- Rubber pad inlay  
NBR (Perbunan®) 80 ±5 shore A, black
- Load Rating Information → page 2118
- Elastomer Characteristics → page 2135
- RoHS compliant

**Information**

The solid rubber pad of GN 32 leveling feet is firmly embedded in the sheet metal base and secured by a screw loctited into place.

The leveling feet can be screwed to the mounting surface using the mounting flange, which prevents lateral slippage.

The black rubber pad inlay (NBR) offers high resistance to swelling when in contact with oils and fuels.

These leveling feet are supplied fully assembled and cannot be disassembled.

<p>How to order (Inch)</p> <p><b>GN 32-60-5/8X11-53-A1-X</b></p>	1	Base diameter d <sub>1</sub>
	2	Thread d <sub>2</sub>
	3	Length l <sub>7</sub> (Length l <sub>1</sub> )
	4	Type (Base)
	5	Stud / socket version

<p>How to order (Metric)</p> <p><b>GN 32-100-M20-150-A1-U</b></p>	1	Base diameter d <sub>1</sub>
	2	Thread d <sub>2</sub>
	3	Length l <sub>1</sub> (Length l <sub>7</sub> )
	4	Type (Base)
	5	Stud / socket version

3.1  
3.2  
3.3  
3.4  
3.5  
3.6  
3.7  
3.8  
3.9  
3.10

