

Construction and Assembly Instructions

Installation hole for punching or laser machining

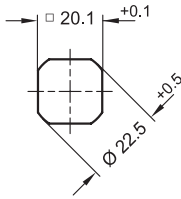

Installation hole for drilling or milling

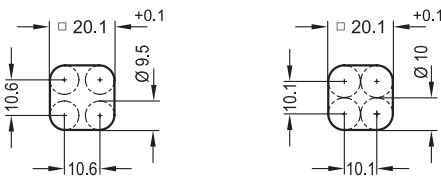

Assembly latch and hook

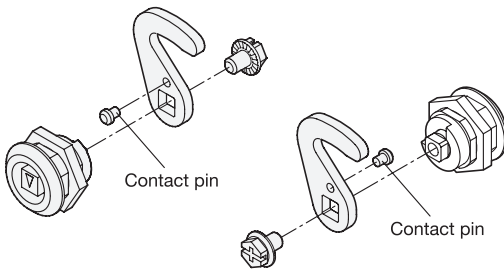

Dimensions of the latch bracket

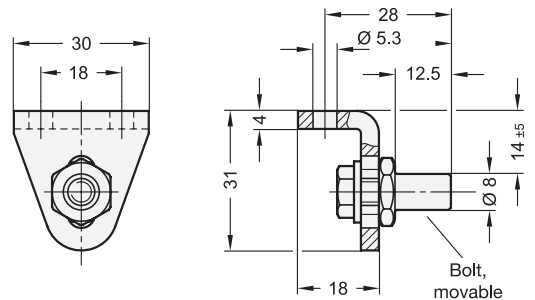

Page

GN 115.8 Cam Latches with Hook, Housing Zinc Die-Cast, with Operating Elements	XYZ
GN 115.8 Cam Locks with Hook, Housing Zinc Die-Cast	XYZ

3.1
3.2
3.3
3.4
3.5
3.6
3.7
3.8
3.9
3.10

