

Regarding the mounting options and external architecture, EN 9054 electronic position indicators with LCD display are very similar to EN 954 mechanical position indicators and can normally be substituted for the latter.

The special advantage of the electronic position detection lies in the programming capability of the display options of the position indicator. Using the 3 operating buttons, the following settings may be selected:

- Selecting between incremental or absolute measurement mode
- Changing the unit of measure (mm, inch or degree)
- Resetting the counter or selecting a predefined offset value
- Changing the display after one turn of the shaft
- Determining the resolution, i.e. the number of decimal points displayed
- Determining the direction of rotation / direction of counting
- Determining the display orientation (as a factor of the installation position)
- Specifying the maximum speed of rotation

The installed lithium battery has a life of over 5 years. Time to replace the battery is indicated by a symbol on the display. Battery replacement is easy - simply remove the front cover.

Due to the high protection class IP 65 or IP 67, the position indicator is suitable for applications in which frequent washing is required, including even direct water jet exposure.

Other important details and tips are given in the operating instructions for EN 9054 position indicators which are included with every position indicator. Instructions are also available as PDF downloads from "www.jwwinco.com" under "Service".

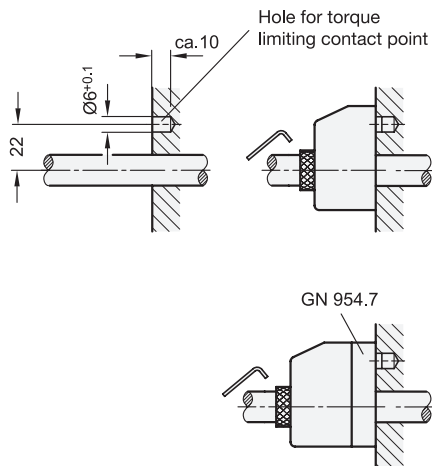

Installation instructions

Before installation of the position indicator, a bore hole for the torque limiting contact point is to be drilled, as shown in the adjacent drawing.

With **EN 952.1 mounting adaptors** → page 388 the hollow shaft (with bore 14 H7) of the position indicator can be adapted to fit the spindle.

If a reduction in the diameter of the hollow shaft is to be made at the same time as mounting a control knob, **GN 957 control knobs** → page 389 are available which combine both functions in a single component (no adaptor bushings required).

The position indicator is mounted with the torque limiting contact point inserted in the bore hole, to stabilize the housing in place. The hollow shaft is mounted to the spindle and secured with the set screw.

With **GN 954.7 clamping plates** → page 390 spindles can be clamped and secured after adjusting.