

Mounting examples

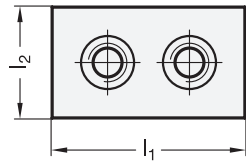
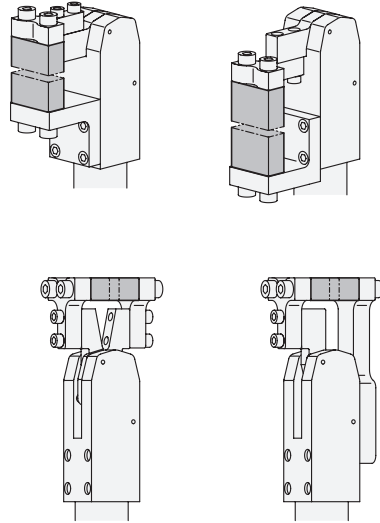

Metric table

Dimensions in: millimeters - inches

¹ l ₁	² h		d ₁ Thread	d ₂ ^{HB} / _{hb}	l ₂	l ₃ ±0.01	t
30 1.18	25 .98	50 1.97	M 6	9 .35	13 .51	17 .67	8 .31
40 1.57	35 1.38	70 2.76	M 8	11 .43	17 .67	23 .91	12 .47
50 1.97	45 1.77	80 3.15	M 10	13 .51	20 .79	30 1.18	15 .59
60 2.36	50 1.97	85 3.35	M 10	13 .51	20 .79	40 1.57	15 .59

Specification

- Jaw block
Steel C45, blackened finish
- *ISO-Fundamental Tolerances* → page QVX
- **RoHS compliant**

Accessory

- Centering guide bushings GN 870 → page QVX

Information

GN 872 jaw blocks are designed to be modified by the user into individual clamping designs, such as prisms and radii. They are also suitable for welding.

The fastening thread and centering holes are adapted to the dimensions of the clamping arms and brackets of the GN 864 / GN 864 / GN 866 pneumatic fastening clamps to enable quick and easy assembly.

GN 870 centering guide bushings are **not** included and need to be ordered separately.

<p>How to order</p> <p>¹ ²</p> <p>GN 872-50-80</p>	1 Length l ₁
	2 Height h

1.1
1.2
1.3
1.4
2.1
2.2
2.3
2.4

