

2 Type
BI Vertical clamping arm

Metric table

Dimensions in: millimeters - inches

Size (Piston Ø)	Max. clamping moment in Nm at 6 bar	F _H Holding capacity at r at 6 bar	F _S Clamping force at r at 6 bar	a	b -0.2	d ₁ h8	d ₂ Thread	d ₃ H8	d ₄	d ₅ Thread	h ₁	h ₂	l ₁ -0.5
20	60	2300 N 517 lbf	1250 N 281 lbf	10.5 0.41	10 0.394	28 1.102	M 5	7 0.276	4.2 0.17	M 5	16 0.63	16 0.63	150 5.91
32	150	3040 N 683 lbf	2220 N 499 lbf	15.5 0.61	12 0.472	40 1.575	M 6	9 0.354	5 0.20	G 1/8	21 0.83	21 0.83	206 8.11
40	300	4060 N 913 lbf	3640 N 818 lbf	18.5 0.73	16 0.630	50 1.969	M 8	11 0.433	6.8 0.27	G 1/8	26 1.02	26 1.02	244 9.61
50	475	7200 N 1619 lbf	4900 N 1102 lbf	21.5 0.85	18 0.709	60 2.362	M 10	13 0.512	8.5 0.33	G 1/8	31 1.22	31 1.22	279 10.98

Size (Piston Ø)	l ₂ -0.5	l ₃	l ₄	l ₅	l ₆	l ₇ -0.5	m ₁ ±0.01	m ₂	m ₃ ±0.01	m ₄ ±0.01	m ₅ ±0.01	m ₆	r	s	t
20	171 6.73	70 2.76	21 0.83	4.5 0.18	21 0.83	97 3.82	12 0.4724	7.5 0.30	17 0.6693	34 1.3386	22 0.8661	13 0.51	47.5 1.87	32 1.26	13 0.51
32	237 9.33	91 3.58	31 1.22	6 0.24	31 1.22	133 5.24	18 0.7087	10 0.39	25 0.9843	51 2.0079	30 1.1811	22 0.87	67.5 2.66	42 1.65	15 0.59
40	282 11.10	104 4.09	38 1.50	7.5 0.30	38 1.50	155 6.10	22 0.8661	13 0.51	30 1.1811	62 2.4409	37 1.4567	25 0.98	82.5 3.25	52 2.05	18 0.71
50	323 12.72	110.5 4.35	44 1.73	8 0.31	44 1.73	174 6.85	27 1.0630	12 0.47	47 1.8504	71.5 2.8150	44 1.7323	35 1.38	96.5 3.80	62 2.44	21 0.83

Specification

- Clamp
Steel C45
Chemically nickel plated **NC**
- Max. pressure 10 bar
- ISO Fundamental Tolerances → page 2129
- RoHS compliant

On request

- With nonstick coating for protection against welding spray and corrosion

Information

The maximum clamping moment of GN 865 pneumatic fastening clamps is reached once the clamping arm is at the end of its stroke. For this reason the working stroke should be completed as closely as possible to the stroke end.

see also...

- List of Pneumatic Clamps → page 834
- Operating Principle / Mounting Methods → starting from page 864
- Centering Guide Bushings GN 870 → page 875
- Sensors GN 893.1 / GN 893.2 / GN 893.3 / GN 893.4 → page 876
- Single Post Coupling / Y-Coupling Accessories GN 867 → page 870

How to order

GN865-40-BI-NC

1	Size
2	Type
3	Finish

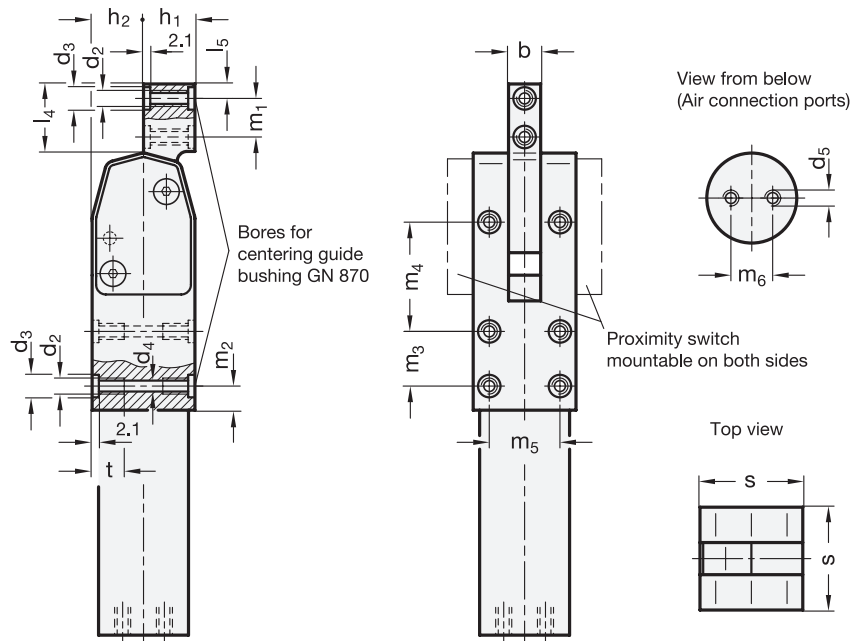

Installation examples

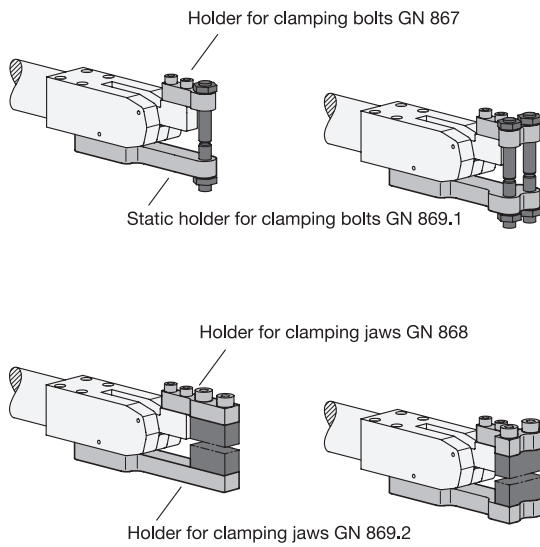

Principle of operation

