

2 Type
BL Horizontal clamping arm

Metric table

1

Dimensions in: millimeters - inches

Size (Piston Ø)	Max. clamping moment in Nm at 6 bar	F _H Holding capacity at r at 6 bar	F _S Clamping force at r at 6 bar	a	b -0.2	d ₁ h8	d ₂ Thread	d ₃ H8	d ₄	d ₅ Thread	h ₁	h ₂
20	60	4070 N 915 lbf	2220 N 499 lbf	27 1.06	10 0.394	28 1.102	M 5	7 0.276	4.2 0.17	M 5	16 0.63	51 2.01
32	150	5620 N 1263 lbf	4110 N 924 lbf	36.5 1.44	12 0.472	40 1.575	M 6	9 0.354	5 0.20	G 1/8	21 0.83	75.5 2.97
40	300	7530 N 1693 lbf	6740 N 1515 lbf	44.5 1.75	16 0.630	50 1.969	M 8	11 0.433	6.8 0.27	G 1/8	26 1.02	91.5 3.60
50	475	13300 N 2990 lbf	9000 N 2023 lbf	52.5 2.07	18 0.709	60 2.362	M 10	13 0.512	8.5 0.33	G 1/8	31 1.22	114 4.49

Size (Piston Ø)	l ₁ -0.5	l ₂	l ₃	l ₄	l ₅	m ₁ ±0.01	m ₂	m ₃ ±0.01	m ₄ ±0.01	m ₅	r	s	t
20	150 5.91	37.5 1.48	70 2.76	21.5 0.85	4.5 0.18	12 0.4724	7.5 0.30	17 0.6693	22 0.8661	13 0.51	27 1.06	32 1.26	13 0.51
32	206 8.11	52 2.05	91 3.58	31 1.22	6 0.24	18 0.7087	10 0.39	25 0.9843	30 1.1811	22 0.87	36.5 1.44	42 1.65	15 0.59
40	244 9.61	63 2.48	104 4.09	37 1.46	7.5 0.30	22 0.8661	13 0.51	30 1.1811	37 1.4567	25 0.98	44.5 1.75	52 2.05	18 0.71
50	279 10.98	74 2.91	110.5 4.35	43 1.69	8 0.31	27 1.0630	12 0.47	47 1.8504	44 1.7323	35 1.38	52.5 2.07	62 2.44	21 0.83

Specification

- Clamp
Steel C45
- Chemically nickel plated **NC**
- Nonstick coating
Polytetrafluorethylene (PTFE), green **FG**
- Max. pressure 10 bar
- ISO Fundamental Tolerances → page 2129
- Plastic Characteristics → page 2135
- RoHS compliant

Information

The maximum clamping moment of GN 864 pneumatic fastening clamps is reached once the clamping arm is at the end of its stroke. For this reason the working stroke should be completed as closely as possible to the stroke end.

The type FG is equipped with a nonstick coating of polytetrafluorethylene (PTFE) for protection against welding spray and corrosion. With GN 864.1 protective covers, the tensioning mechanism can be protected against penetrating dirt.

see also...

- Operating Principle / Mounting Methods → page 864
- Information on Pneumatic Fastening Clamps (Mounting Methods / Accessories) → page 865

How to order (Chemically nickel plated)

GN864-20-BL-NC

- Size
- Type
- Finish

How to order (Nonstick coating)

GN864-40-BL-FG

- Size
- Type
- Finish

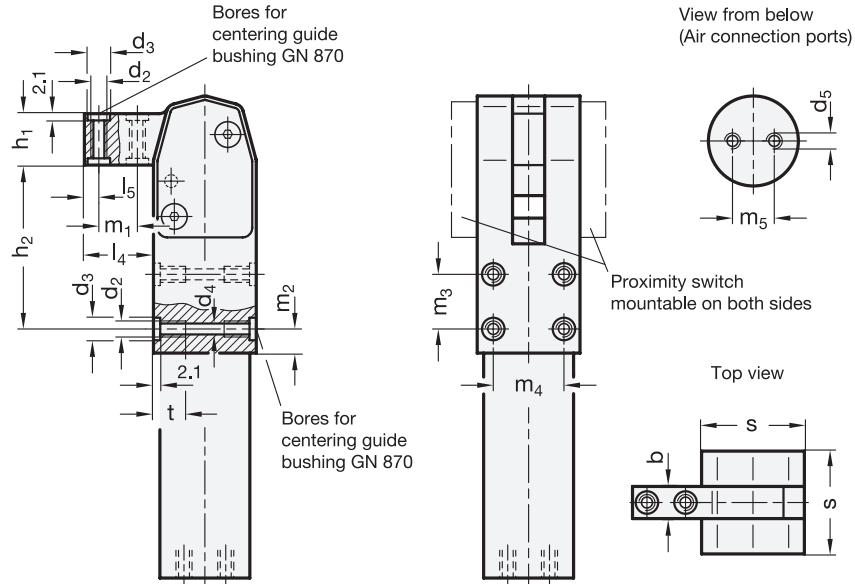

Installation examples

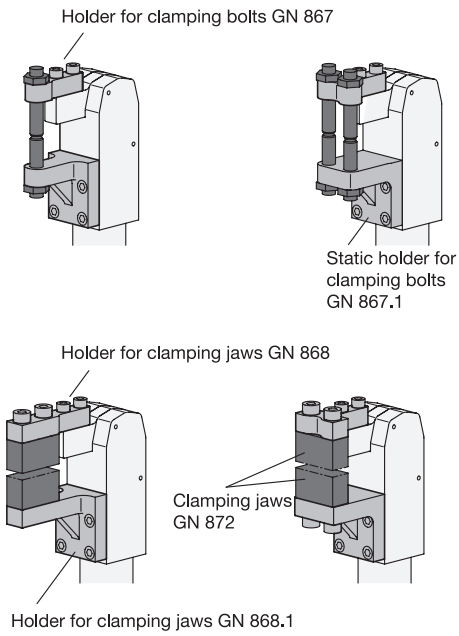

Principle of operation

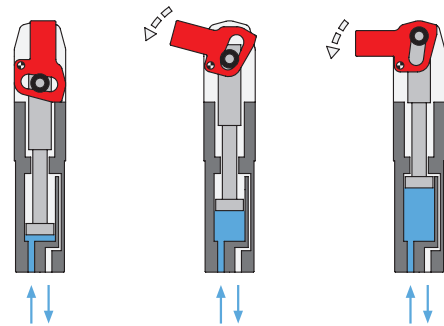

1.1
1.2
1.3
1.4
1.5
2.1
2.2
2.3
2.4

